

FCD-E1A

E1 or Fractional E1 Access Unit



Managed access for E1 and fractional E1 services

- One or two data ports with selectable sync data rates: $n \times 56$, $n \times 64$ kbps
- Optional sub-E1 drop-and-insert user port for PBX connectivity
- Failure-immune sub-E1 port ensuring uninterrupted service (G.703 only)
- Optional Fast Ethernet bridge, with VLAN support
- Dial-in option for remote out-of-band management

FCD-E1A is an access unit for E1 or fractional E1 services. It can be used as a rate and interface converter, or as an integrating multiplexer for E1 and fractional E1 services (see *Figure 1 and Figure 2*).

FCD-E1A operates opposite RAD's modular DXC or Megaplex multiservice access nodes or other vendors' E1 equipment, for multilink star applications such as SDH network access. DXC/Megaplex and FCD-E1A units operate together under centralized SNMP network management (see *Figure 3*).

FCD-E1A is supplied with a standard electric (G.703) E1 main link. An optional sub-E1 drop-and-insert port is also available. The unit can be ordered with either one or two data ports. Alternatively, an Ethernet bridge port is available instead of a second data port.



FCD-E1A

E1 or Fractional E1 Access Unit

The basic unit includes a wide range power supply, one E1 main link, and one data port.

The electrical E1 interface is compatible with virtually all carrier-provided E1 services and meets ITU recommendations G.703, G.704, G.706, and G.732. It supports both 2 and 16 frames per multiframe, with or without CRC-4. Line coding is HDB3. The integral LTU (soft-configurable) ensures a range of up to 2 km (1.2 miles).

The optional sub-E1 port can be configured to work without CRC-4, while the E1 main link is working with CRC-4. This allows non-CRC-4 E1 equipment to be connected over an E1 network that is using CRC-4.

Bypassing the sub-E1 port to the G.703 main link (electric only) ensures uninterrupted service to the sub-E1 port and provides immunity from hardware or power failures.

Timeslot assignment is programmable, allowing data from each data or sub-E1 port to be placed automatically into consecutive timeslots. Alternatively, the user can assign timeslots manually.

Multiple clock source selection ensures maximum flexibility for supporting different applications. The E1 main link may derive its timing from the recovered receive clock, from an internal oscillator, from one of the data ports, or from the sub-E1 port.

ISDN dial backup ensures the continuity of data services.

FCD-E1A is a standalone unit. An optional rack mount adapter kit enables installation of one or two side-by-side units in a 19-inch rack (see *Ordering*).

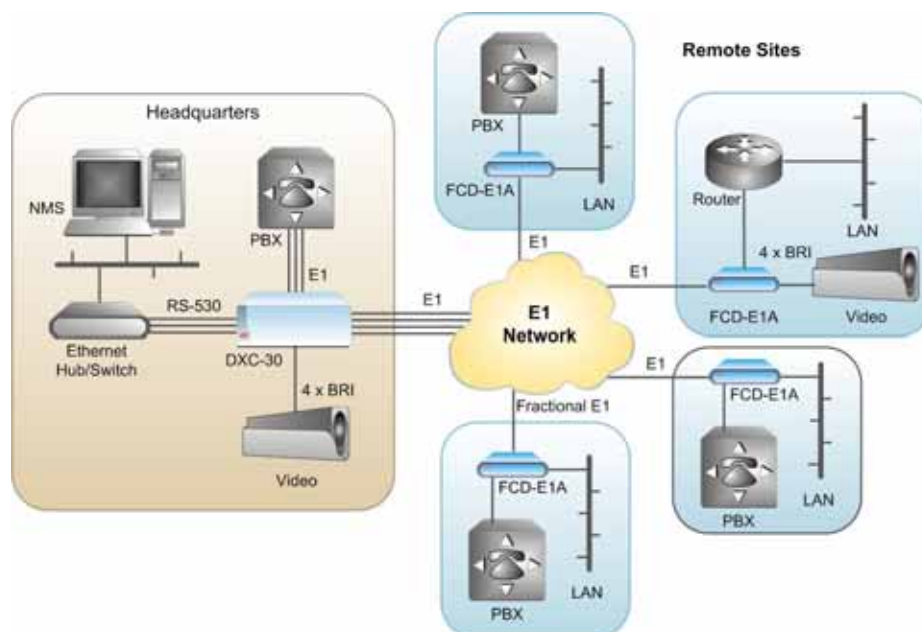

Figure 1. Extended Ethernet Management over E1 Network

USER INTERFACES

The following interfaces can be ordered for the data port: V.35, RS-530, V.36/RS-449, or X.21.

An optional second data port can be ordered with V.35, RS-530, V.24, V.36/RS-449, or X.21 and IR-ETH/QN interfaces.

The synchronous data ports can operate in the following clock modes:

- **DCE:** FCD-E1A provides both transmit and receive clocks to the user equipment, with optional sampling of the incoming data with an inverted clock.
- **DTE1:** FCD-E1A provides the transmit clock. The connected user equipment provides receive clock (not for X.21).
- **DTE2:** The connected user equipment provides both transmit and receive clocks (not for X.21).

When equipped with an IR-ETH/QN interface module, FCD-E1A transparently connects remote LANs, as well as VLANs, over the E1 links. It filters Ethernet packets, forwarding only packets destined to the WAN.

The IR-ETH/QN port has a 10/100BaseT interface that supports autonegotiation and VLAN frames.

The optional four ISDN "S" interfaces can extend ISDN services to locations that do not support ISDN. Each "S" interface port operates in full-duplex mode over a 4-wire twisted-pair at a range of up to 1000m (3300 ft).

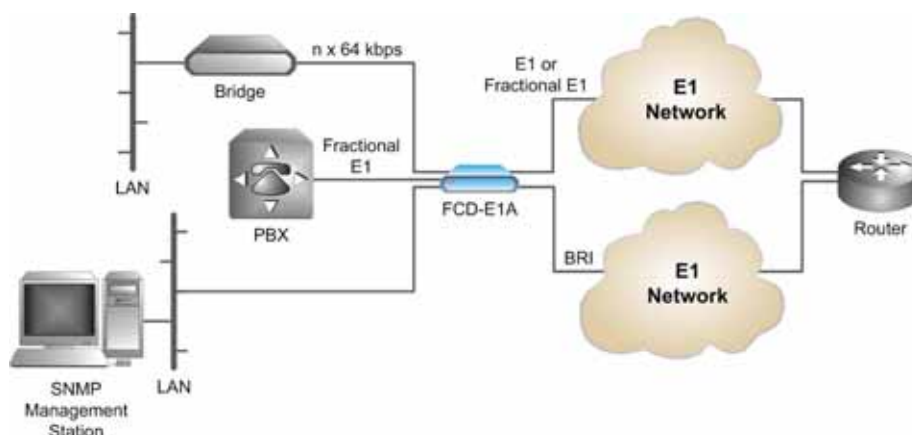

Figure 2. Co-connection of LAN and PBX Traffic to E1 Network

FCD-E1A

E1 or Fractional E1 Access Unit

MANAGEMENT & MAINTENANCE

Status and diagnostic information is defined, configured, and monitored using one of the following methods:

- Menu-driven management using the front panel LCD with three pushbuttons.
- ASCII terminal connected to the SLIP control port
- SNMP or Telnet management through either the SLIP control port or inband

The internal SNMP agent can be controlled by the RADview SNMP network management application or any generic SNMP station.

FCD-E1A supports both dial-in and dial-out modem connections. These connections allow remote out-of-band configuration and monitoring, as well as sending callout alarm messages. Modems can be connected using the serial V.24 SLIP, PPP, or Ethernet ports.

Inband management uses the spare bits (S_a bits) on timeslot 0 (TS0) or a dedicated timeslot with standard protocols: Frame Relay (RFC 1490), PPP, and standard RIP2 routing. If spare bits on TS0 are used for management access, they must be passed transparently end-to-end.

Maintenance capabilities include user-activated local and remote loopbacks on the E1 main link, sub-E1, and data ports. The user can activate a BER test for the sub-E1 port and each data port individually.

Each data port responds to an ANSI FT1 inband loop code (RDL) generated by a remote FCD-E1A or DXC in a specific bundle of timeslots allocated only to that port.

E1 network statistics are stored in memory according to RFC-1406 and can be retrieved locally through the control port.

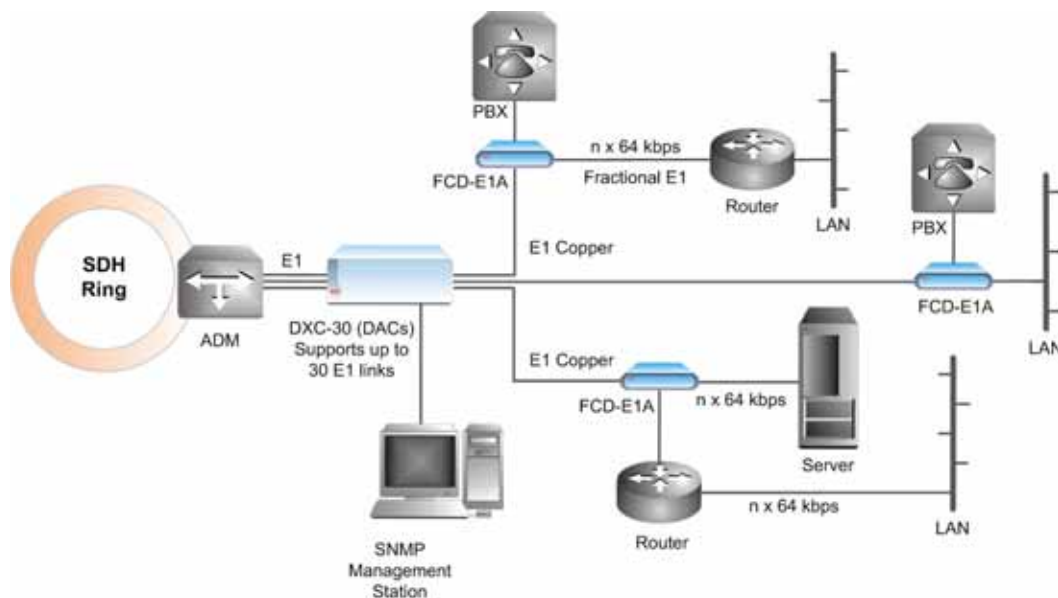

Figure 3. SDH Access Solution for Multiple Remote Sites

Specifications

ELECTRIC E1 MAIN LINK (NETWORK) AND SUB-E1 PORTS

Framing

256N (no MF, CCS)
 256N with CRC-4 (no MF, CCS)
 256S (TS16 MF, CAS)
 256S with CRC-4 (TS16 MF CAS)
 Unframed

Bit Rate

2.048 Mbps

Line Code

HDB3

Impedance

120Ω, balanced
 75Ω, unbalanced

Signal Level

Receive:

0 to -36 dB with LTU
 0 to -10 dB without LTU

Transmit:

±3V (±10%), balanced
 ±2.37V (±10%), unbalanced

Jitter Performance

As per ITU G.823,
 ETSI TBR-12, TBR-13

Connectors

RJ-45, 8-pin, balanced
 Two BNC coaxial, unbalanced

Transmit Timing

Locked to the system clock

Compliance

ITU G.703, G.704, G.706, G.732

Performance Monitoring (Main Link only)

Local support of CRC-4
 Statistics according to RFC-1406

DATA PORTS

Number of Data Ports

One or two (see *Ordering*)

Interfaces

V.35, RS-530, V.36, X.21
 V.24 (data port 2 only)

Connectors

D-type 25-pin RS-530, female

Data Rate

$n \times 56$ or $n \times 64$ kbps, (n=1 to 31)

Clock Modes

DCE: Rx and Tx clock to DTE
 DTE1: Rx clock to user device,
 Tx clock from user device
 DTE2: Rx and Tx clock from DCE

Control Signals

CTS follows RTS or constantly ON,
 soft-selectable
 DSR constantly ON, unless in test mode
 DCD constantly ON, unless in SYNC LOSS

ETHERNET BRIDGE PORT

Interface Module

IR-ETH/QN

LAN Table

1,000

Filtering and Forwarding

150,000 frame/second

Buffer

85 frames

Line Code

10BaseT: Manchester
 100BaseT: MLT3

WAN Protocol

HDLC

Compliance

IEEE 802.3/Ethernet V2, 802.1Q (relevant parts), 802.1p and 802.3x.

Connector

Shielded RJ-45

FCD-E1A

E1 or Fractional E1 Access Unit

"S" INTERFACE PORTS

Number of Ports

Four "S" 2B+D interface channels

Compliance

ETS 300012

Interface

4-wire, full-duplex

Bit Rate

192 kbps \pm 100 ppm

Line Code

Pseudoternary

Line Termination

100 Ω \pm 5%

Range

1000m (3300 ft)

Signal Levels

Receive: +1.5 to -7.5 dB relative to the nominal amplitude

Transmit: \pm 750 mV

Timing Modes

NT: Transmit timing is locked to system timing clock

TE: Looped back towards the "S" interface (timing is derived from Rx signal from the ISDN switch NT)

Connector

RJ-45 (8-pin) per channel

Power Feeding Voltage

38V (\pm 4V), as per TR5805-3074, 1W per channel

MANAGEMENT PORTS

CONTROL DCE Port

Interface and connector: V.24/RS-232, 9-pin D-type, female

Format: Asynchronous

Baud rate: 1.2–19.2 kbps, autobaud

Character: 8 bit no parity, 7 bit odd, or even parity

CONTROL Port (Serial)

Connector: V.24/RS-232, 9-pin D-type, female

Format: Asynchronous

Baud rate: 0.3–57.6 kbps, autobaud

Character: 8 bit no parity, 7 bit odd or even parity

CONTROL Port (Ethernet)

Type: Ethernet 10BaseT

Connector

RJ-45

GENERAL

System Clock

Internal clock: \pm 30 ppm

Loopback timing (sub, main E1): \pm 130 ppm

External timing from data port: $n \times 56$, $n \times 64$ kbps \pm 130 ppm

Diagnostics

Main E1 link:

Local and remote loopbacks

Inband code loopback

Sub-E1 port:

Local and remote loopbacks

BER test

Data port:

Local and remote loopbacks

BER test

Timeslot Allocation

Consecutive (bundled)
User-defined

Front Panel Control

LCD: 2 rows of 16 characters
Push buttons: Cursor, Scroll, Enter

Indicators

General: TST, ALM
Main E1: LOC SYNC LOSS, REM SYNC LOSS
Sub-E1: LOC SYNC LOSS, REM SYNC LOSS
All indicators are red except TST (yellow).

Alarms

Last 100 alarms are stored and available for retrieval. Each alarm is time-stamped.

Alarm Relay

3 relay contacts on the alarm relay port
Activated by alarms in the user-defined alarm buffer

Physical

Height: 4.3 cm (1.7 in) (1U)
Width: 21.5 cm (8.5 in)
Depth: 24.3 cm (9.5 in)
Weight: 1.3 kg (2.9 lb)

Power Supply





Wide range AC/DC: 100 to 240 VAC,
-48 to -60 VDC

Nominal power consumption: 5W max.

Environment

Temperature: 0°C to 50°C (32°F to 122°F)
Humidity: up to 90%, non-condensing

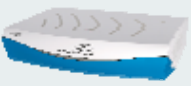
Table 1. FCD Comparison Table

Features	FCD-E1	FCD-E1L	FCD-E1LC/T1LC	FCD-E1E	FCD-E1A
					
Total user ports	3	2	3	2	3
Interface types	RS-530, V.35, V.36, X.21, Sub-E1	RS-530, V.35, V.36, X.21, Ethernet bridge (10/100BaseT with VLAN support)	RS-530, V.24, V.35, V.36, X.21, Ethernet Bridge (10/100BaseT with VLAN support), Sub-E1/T1	RS-530, V.35, V.36/RS-449, X.21, V.24/RS-232, Ethernet Bridge (10/100BaseT with VLAN support), Sub-E1	RS-530, V.35, V.36/RS-449, X.21, Sub-E1
E1/T1 line type	Copper	Copper	Copper	Copper	Copper
LCD panel	✓	–	–	✓	✓
Auto-configuration	–	✓	–	–	–
SNMP management	✓	✓	✓	✓	✓
Interoperability	Megaplex, DXC	Megaplex, DXC	Megaplex, DXC	Megaplex, DXC	Megaplex, DXC
ETH out-of-band for management	✓	✓	✓	✓	✓
E1 bypass	✓	–	–	✓	✓
ETH performance	–	VLAN transparent	VLAN transparent	VLAN priority tagging (802.1p/Q)	VLAN transparent

FCD-E1A

E1 or Fractional E1 Access Unit

Ordering

STANDARD CONFIGURATIONS

FCD-E1A/AC/UTP/X21/S0

FCD-E1A/S1/AC/UTP/X21/X21

FCD-E1A/S1/AC/UTP/V35/S0

FCD-E1A/S1/AC/UTP/X21/S0

FCD-E1A/AC/UTP/V35/S0

SPECIAL CONFIGURATIONS

FCD-E1A/*/~/\$/&/%

Legend

- * Optional drop & insert sub-E1 port.
(Default= no sub-E1 port)
- S1** Sub-E1 port
- ~ Power supply type:
 - AC** 110 VAC to 240 VAC
 - 48** -48 VDC
- \$** Management port interface:
 - V24** V.24/RS-232 (DB-9)
 - UTP** Ethernet 10BaseT (UTP)
- &** Data port interface:
 - 530** RS-530
 - V35** V.35
 - X21** X.21
 - 449** V.36/RS-449
- %** Second data port interface
(Default=single port):
 - 530** RS-530
 - V24** V.24
 - V35** V.35
 - X21** X.21
 - 449** V.36/RS-449
- ETQN** IR-ETH/QN UTP Ethernet bridge
VLAN (10/100BaseT)
- S0** 4xS0 ISDN

SUPPLIED ACCESSORIES

AC power cord

AC/DC adaptor plug

The following cables (suitable for use in DCE clock mode only) are supplied for each data port interface specified. Cable length is 2m (6 ft):

CBL-HS2/^

Adapter cables for DB-25 channel connectors for use in DCE clock mode only

Note: Cable length is 2m (6 ft).

Legend

- ^ Data port interface:
 - V/1** 34-pin V.35
 - R/1** 37-pin V.36/RS-449
 - X/1** 15-pin X.21

OPTIONAL ACCESSORIES

RM-17

Hardware kit for mounting one or two units side-by-side in a 19-inch rack

CBL-HS2/*/#

Adapter cables for DB-25 channel connectors for use in DTE clock mode only

Legend

- * Interface, clock mode:
 - V/2** for 34-pin V.35, DTE1
 - V/3** for 34-pin V.35, DTE2
 - R/2** for 37-pin V.36/RS-449, DTE1
 - R/3** for 37-pin V.36/RS-449, DTE2
- # Cable connector type:
 - F** Female
 - M** Male

International Headquarters
24 Raoul Wallenberg Street
Tel Aviv 69719, Israel
Tel. 972-3-6458181
Fax 972-3-6498250, 6474436
E-mail market@rad.com

North America Headquarters
900 Corporate Drive
Mahwah, NJ 07430, USA
Tel. 201-5291100
Toll free 1-800-4447234
Fax 201-5295777
E-mail market@rad.com

www.rad.com

Order this publication by Catalog No. 803182



data communications

The Access Company